



Company Profile



Bhuasuni Precast Private Limited

Bidanasi, Bandha Chhak, Cuttack-753014
Phone : 0671-2504594(O) , 94398 14949(M)
bhuasuniprecast@gmail.com
www.bhuasuniprecast.com

Why to use PRECAST Concrete Products



These are numerous reasons as to why precast concrete product is beneficial. They are strong efficient and easy to install. Used for thousands of years precast concrete has stood the test of time while evolving to become even more versatile. Some advantages are:

Durability: Studies have shown that precast concrete product can provide a service time more than 100 years, reducing maintenance and operating cost.

Safety: Precast concrete product is non-combustible with built in fire resistant capability. It creates a safe envelope that helps protect people, equipment and building itself

Easy Installation: Precast concrete product save time .They arrive at your job site ready to install

OTHER ADVANTAGES INCLUDE

- Off-Site manufacturing means stricken quality and safety control. Therefore resulting in better quality and more durable products
- Fasten construction time.
- Less from worksite Clutter, Propping and Temporary works, this in turn leads to better site
- Management, lower costs and increased safety.
- Long spans especially for pre stressed beams.
- Less weather dependency.
- Can be entirely environment friendly.

Opportunities
for good
architecture



BHUASUNI PRECAST PRIVATE LIMITED (BPPL) uses its high-end technology to create precast products. BPPL has been established as a prominent manufacturer and supplier of precast product in Eastern and Central Odisha, specifically the SFRC (Steel Fiber Reinforced Concrete) products. The company is in this business since 1996.

Mission

To be the leader in the market by efficiently and effectively providing a full range of the high quality concert product, services and solution at competitive price focusing on our client's needs and continuously enhancing our product and services through safe, sustainable and innovative manufacturing practices.

Core Value

At "BPPL" we aim to always achieve customer's happiness by performing consistently and delivering value added services to our customers with the highest level of quality. We strive to not only meet our commitments and client expectations but to exceed them on every level and deliver exceptional value. We believe in treating our customers with respect and faith, we grow through creativity, invention and innovation. We integrate honesty, integrity & business ethics into all aspects of our business functioning.

Goal

Regional expansion in the field of precast product and develop a strong base of key costumers .Increase the assets and investment of the company to support the development products and services .To built good reputation in the field of precast product and became a key player in the industries.

Quality and Security

BPPL holds an ISO 9001:2015 certification for manufacturing concrete product. We use advanced technology in all our products in order to ensure high quality products and services for our clients. We have our own TESTING LABORATORY for ensure the quality of our products. Our Quality control team is technically advanced and efficient. We test our product in each alternative day for maintain our quality.

Team

We are functional in this field with full dedication and commitment towards our work. Our Team the asset of our company is its diligent and industrious professionals, engineers and technicians. They perform their task with full dedication and sincerity. They are having sound knowledge of casting & fabrication. We use advanced machinery and tools for fabricating & casting of our products.

Our technicians are given training as any advanced technology machinery is being installed in our development plant. Products are manufactured under the strict supervision and guidance of these proficient engineers and technicians.

We continue to give cost-effective, durable, maintenance-free, aesthetic, user-friendly, and eco-friendly precast concrete solutions.

Business Information



Company Name : Bhuasuni Precast Private Limited
Address : Bidanasi, Bandha Chhak,Cuttack-753014
Web Site : www.bhuasuniprecast.com
Email ID : bhuasuniprecast@gmail.com
Telephone : 0671 2504594 (O)
Mobile : 94398 14949
Incorporation Date : March 07, 2017
Registration Number : U26990OR2017PTC026674
Certification : ISO 9001:2015
PAN : AAHCB1155H
GST Number : 21AAHCB1155H1Z6
Annual Sale : 8.80 Crore
Managing Directors : Mr. Ajay Kumar Senapati
Mr. Bijay Kumar Senapati.
Total No. of Employees : 31
No. of Employees at HO : 7
Factory Site : Peerabazar, Jagatpur, Cuttack-754 200
: Patapur, Trisulia, Cuttack-754 005

Company's Authorized Outlets

- Andharua, Chandaka, Bhubaneswar
- Trisulia, Cuttack
- Balakati, Uttara Chaak, Bhubaneswar
- Brahmagiri, Puri
- Mahidharpada, Trinathbazar, Phul Nakhara, Cuttack

OUR VALUED CLIENTS

Industrial Development Corporation, Odisha (IDCO).
National Aluminum Company (NALCO).
Tata Consultant Services (TCS).
East Cost Railway.
Odisha Public Works Department (OPWD).
Central Public Works Department (CPWD).
Larson & Turbo (L&T).
Viswas Groups.
Fiza Enterprises.
Sapoorji & Pallonji Groups
Krishna Builders
R.K.D Construction
Smart India.
B.C bhuyan Construction Pvt Ltd
Z Estate Pvt.Ltd & Z Engineers (BBSR)

OUR PRODUCTS

Pre stressed Precast SFRC Boundary Wall.
Pavers Block.
Kerb Stone, Mile Stone , Ground Post
Precast SFRC Manhole Cover & Frame.
Designer floor Cement Tiles.
Precast U Drain & Cover Slab.
Precast Toilet.
Cement Cover Block.
Precast Door & Window Frame.
RCC Tree Guard.
Precast Garden Bench.
Precast & Pre Stressed Fencing Pole.

PRE STRESSED PRECAST SFRC BOUNDARY WALL

Our boundary wall post and panel are pre stressed, which involves by imposing a predetermined force in to the concrete member by special high tensile steel wires of 4 mm Dia. Prior to hardening of the concrete. As a result, our boundary walls are free from crack, resistance to effect of impact, shock and stress.

We use 0.3 to 0.5 mm steel fiber wires as an additional ingredient, dispersed uniformly at random in small percentage other than OPC cement, aggregates and fine sand.

Our products are

- More Flexural bending Strength up to 3 times more compared to conventional concrete
- More Fatigue resistant up to 1½ times
- Greater resistance to damage in case of heavy impact
- Less permeability i.e. less porous
- Less plastic shrink crack
- Less drying shrink crack

We use advanced methodology for Curing. Our Curing methodology often involves accelerated curing by using Canvas covers and manual water curing.

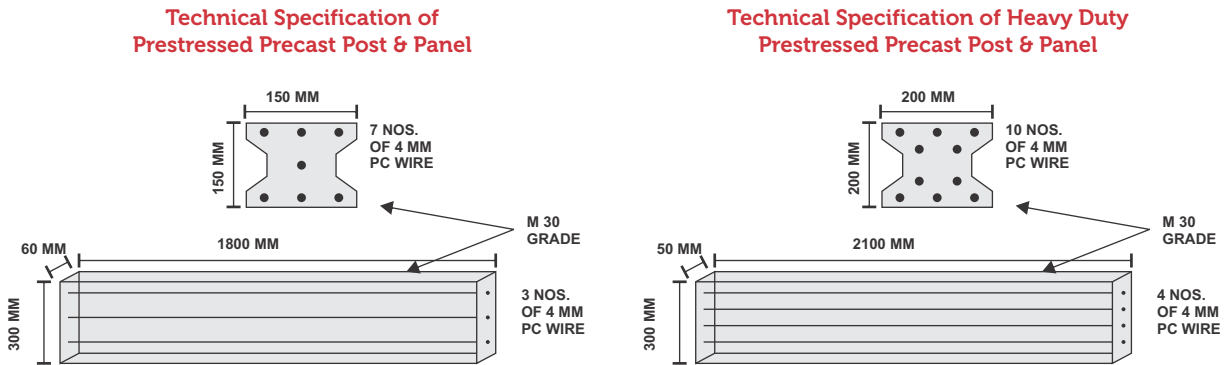

SL.NO.	ITEM NAME	HEIGHT	WIDTH	THICKNESS
1	Pillar Post	3600 MM	200 MM	200 MM
2	Pillar Post	3000 MM	200 MM	200 MM
3	Pillar Post	3000 MM	150 MM	150 MM
4	Pillar Post	2400 MM	150 MM	150 MM
5	Panel	1800 MM	300 MM	45 MM & 50 MM
6	Panel	2100 MM	300 MM	50 MM

Features of the Boundary Wall

- Economic as compared to the traditional brick or similar walls
- Easily erected
- Minimum labor needed
- Better than barbed-wire fencing
- Space saving
- Low maintenance
- Plastering not required
- We can shift wall from one place to another place
- We can decorate it in different shape & Design
- It more safer than bricks boundary wall

Our boundary walls are made from posts erected directly into the ground which have grooves to accommodate textured panels. The panels are available in two varieties, Plain & Design finish. Our boundary wall can be designed in different shape and sizes.

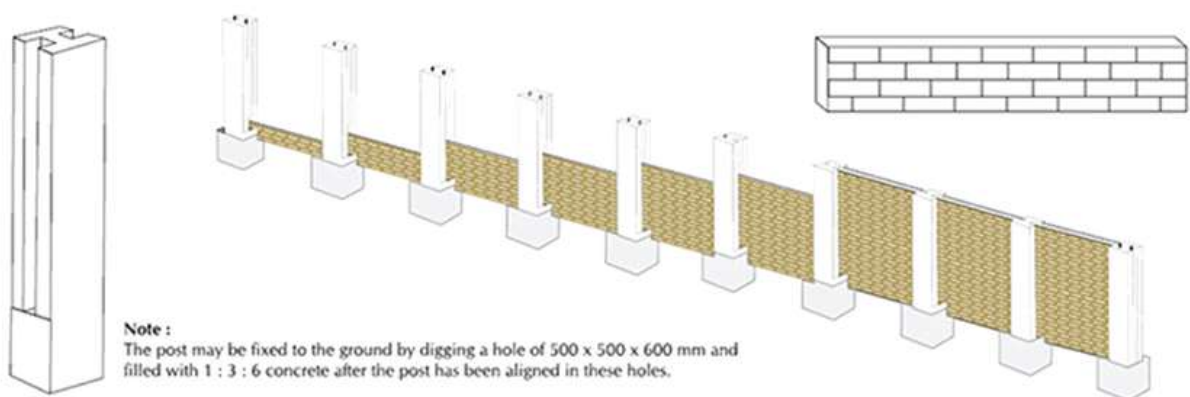
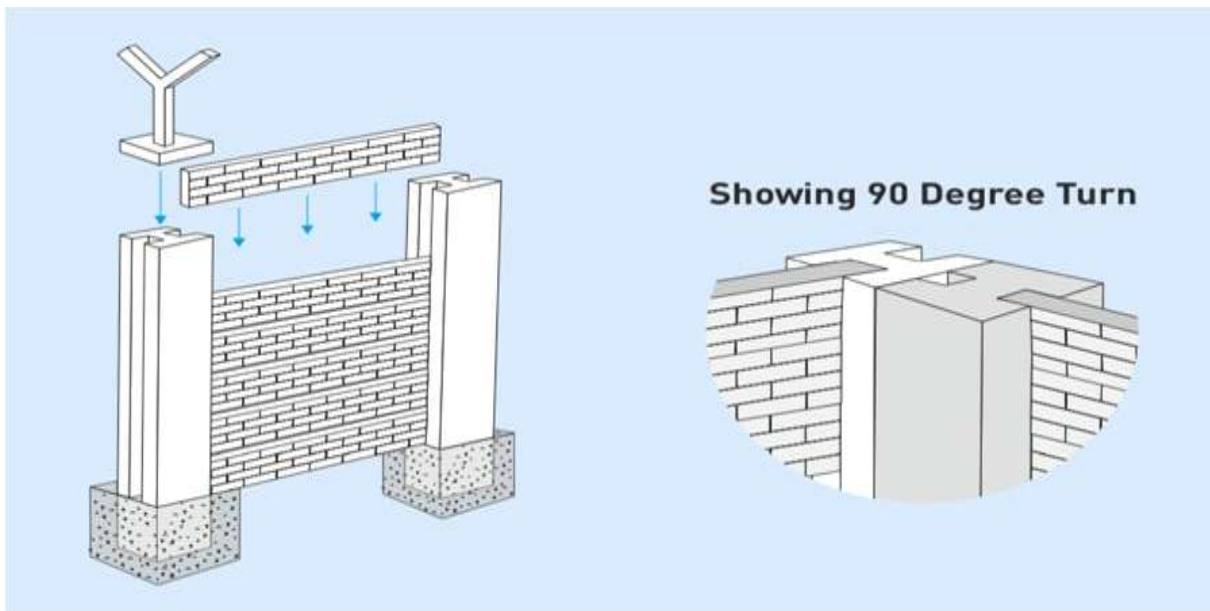



BALANGIR MEDICAL COLLEGE, L & T



**JAYAMANGALA – PUBU SAHI(KHURDA)
INDUSTRIAL ESTATE , IDCO**

**NEW BHUBANESWAR RAILWAY STATION
EAST COST RAILWAY**



CHANDRASEKHAR PUR ,IDCO

S.S CONSTRUCTION (BBSR)

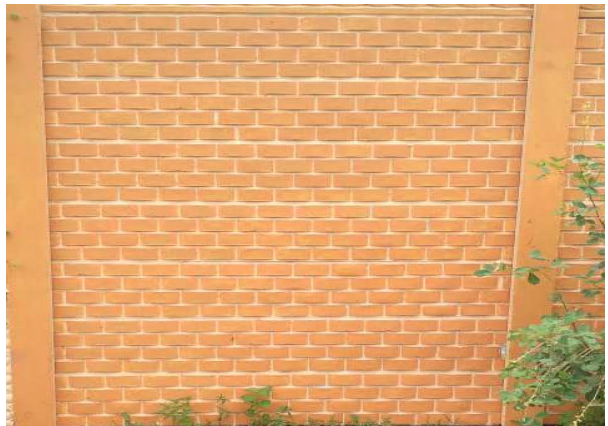
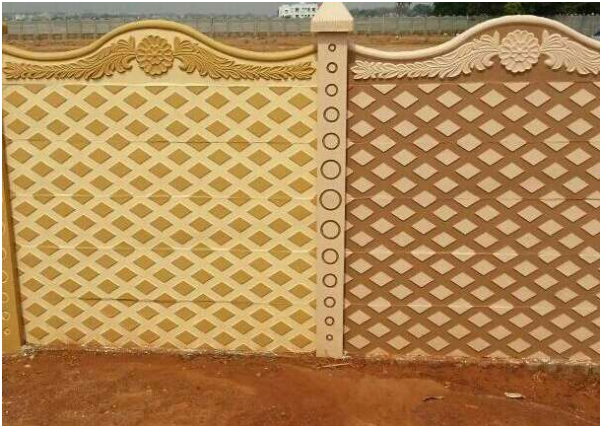

PAVER BLOCKS

We technologically manufacture highly sophisticated range of interlocking Paver Blocks and Grass paver Blocks by using qualitative raw material based on latest technology standards. These interlocking paver blocks are used to offer stylish flooring. We provide our product in a variety of bright colors and numerous patterns. These interlocking paver blocks are one of a kind eco friendly potential product and can be laid without cement bonding so that we can remove and relay to attend below the groundwork.

These are widely used for fulfilling the flooring requirements of various places like houses, offices, Petrol Pumps and institutes parking areas.

Grade of Concrete : **M40** Grade and **M30** Grade.
Thickness : **80 MM** and **60 MM**



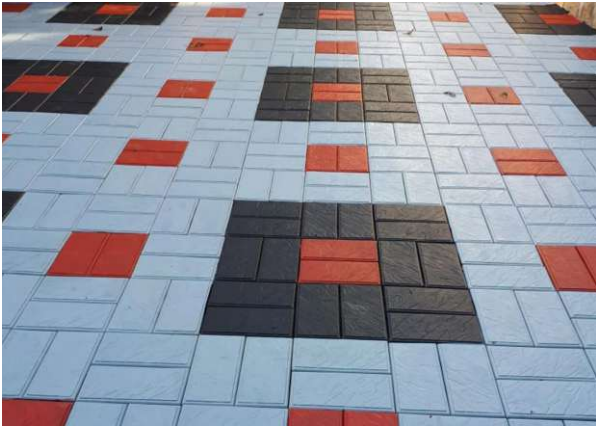

Dimensional Table of Paver

CODE	FIGURE	NAME	THICKNESS	COVERAGE AREA (Per Sq. Ft.)	AVAILABLE COLOUR
BP-1		ASTHRA	60 MM	2 Pieces	Red, Black, Gray & Yellow
BP-2		I BLOCK	60 MM	2.75 Pieces	Red, Black, Gray & Yellow
BP-3		VENUS	60 MM	2 Pieces	Red, Black, Gray & Yellow
BP-4		FANCY ZIG ZAC	60 MM	3 Pieces	Red, Black, Gray & Yellow
BP-5		ZIG ZAC	60 MM	2.80 Pieces	Red, Black, Gray & Yellow
BP-6		V - 3D	60 MM	3 Pieces	Red, Black, Gray & Yellow
BP-7		GEM STONE	60 MM	1.30 Pieces	Red, Black, Gray & Yellow
BP-8		COLORADA	60 MM	2.24 Pieces	Red, Black, Gray & Yellow
BP-9		8"x8" PAVER	60 MM	2.25 Pieces	Red, Black, Gray & Yellow
BP-10		8"x8" STONE PAVER	80 MM	2.25 Pieces	Red, Black, Gray & Yellow
BP-11		HEXAGON	60 MM	0.690 & 1.380 Pieces	Red, Black, Gray & Yellow
BP-12		10"x10" GRASS PAVER	60 MM	1.44 Pieces	Red, Black, Gray & Yellow
BP-13		12"x6" STONE PAVER	60 MM	2 Pieces	Red, Black, Gray & Yellow
BP-14		DYMOD 3-D	60 MM	2.60 Pieces	Red, Black, Gray & Yellow
BP-15		DAMBARU	60 MM	2.250 Pieces	Red, Black, Gray & Yellow
BP-16		JET	60 MM	1.30 Pieces	Red, Black, Gray & Yellow
BP-17		SILICON PAVER	60 MM	2.650 Pieces	Red, Black, Gray & Yellow
BP-18		ROCK PAVER	60 MM	1.440 Pieces	Red, Black, Gray & Yellow
BP-19		KANKAM	60 MM	1.630 Pieces	Red, Black, Gray & Yellow
BP-20		ROUND STONE	60 MM	2.20 Pieces	Red, Black, Gray & Yellow
BP-21		12"x12" GRASS PAVER	60 MM	1.440 Pieces	Red, Black, Gray & Yellow
BP-22		I BLOCK	80 MM	2 Pieces	Red, Black, Gray & Yellow
BP-23		HEXAGON	80 MM	2 Pieces	Red, Black, Gray & Yellow
BP-24		8"x8" STONE PAVER	60 MM	2 Pieces	Red, Black, Gray & Yellow
BP-25		4"x4" STONE PAVER	60 MM	2 Pieces	Red, Black, Gray & Yellow

CURB STONE

We manufacture, supply and export huge assortment of Curb Stones that are widely used in construction sector. The premium quality Curb Stones offered by us have been termed as the best available in the market due to its availability in different shapes and sizes.

M-25 GRADE CONCRETE

HEIGHT	WIDTH	THICKNESS	DESIGN	COLOUR
560 MM	300 MM	150 MM	DOUBLE CURB	Gray
450MM	300 MM	150 MM	TAPERED	Gray
300 MM	300 MM	150 MM	TAPERED	Gray
300 MM	200 MM	150 MM	TAPERED	Gray
300 MM	300 MM	100 MM	TAPERED	Gray
300 MM	300 MM	150 MM	ROUND CURB	Gray
450 MM	300 MM	150 MM	ROUND CURB	Gray

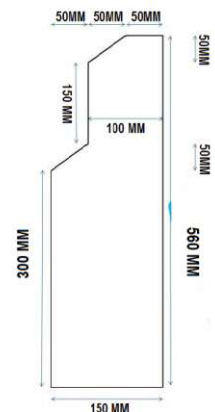
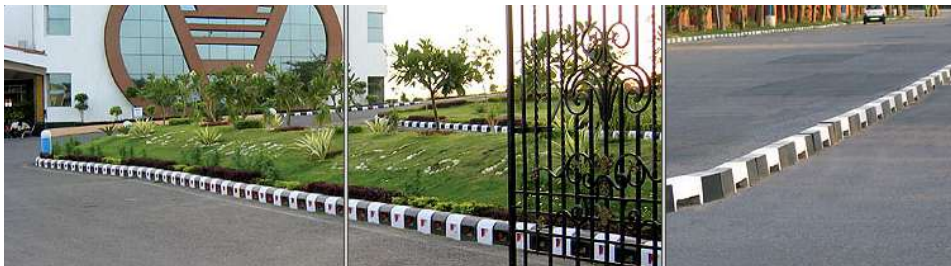
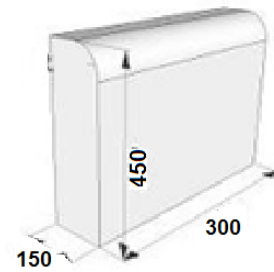
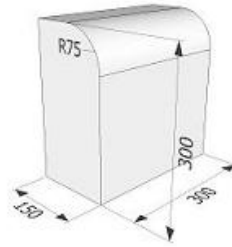
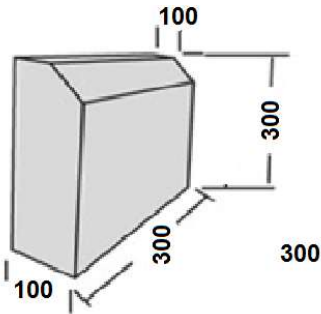
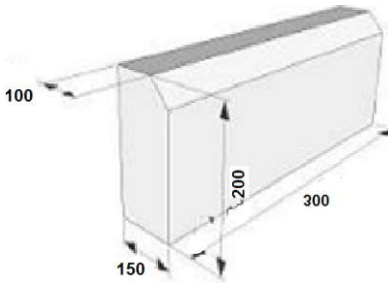

SFRC MANHOLE COVER & FRAME

We are engaged in manufacturing an extensive range of Manhole cover and Frame. These manhole cover round and square manhole cover are designed with medium and heavy manholes for different applications needs. All the major drainage problems in metropolitan cities can be resolved using our array of manhole covers & frames. Our array is also used for drainage, telephone ducts and storm water. These drain covers are manufactured as per the specific demands and needs of our customers.

R.C.C. manhole covers or Concrete Manhole Cover is the best way to check the junction point of two or more drains to clear the blockage in the sewerage & water pipe lines. Manhole cover & frames are manufactured using M30 grade of concrete by vibro compaction process.



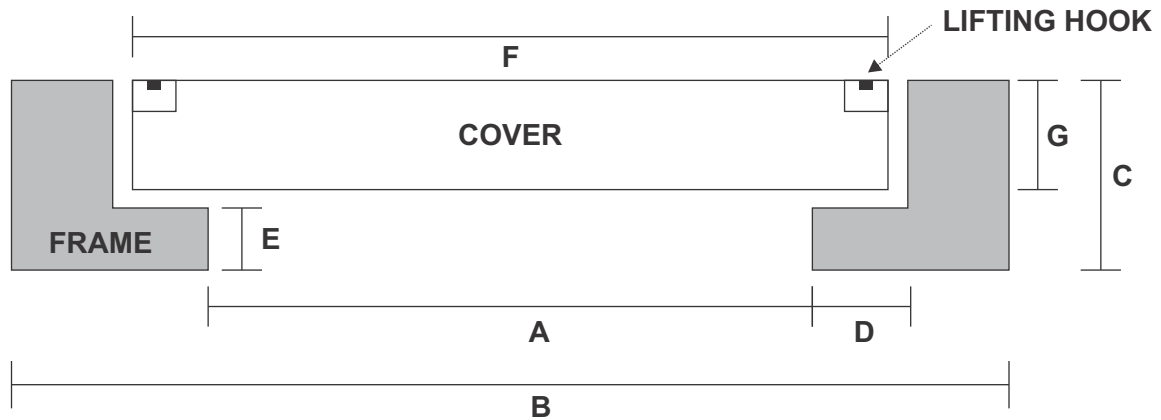

Product Code	Product Description		Shape	Frame Details					Cover Details	
				A	B	C	D	E	F	G
BPCI-1	Extra Heavy Duty	EHD-35	Circular	560	875	175	75	75	720	100
BPCI-2	Extra Heavy Duty	EHD-35	Circular	600	910	175	75	75	760	100
BPCI-3	Heavy Duty	HD-20	Circular	600	910	155	75	75	760	80
BPCI-4	Heavy Duty	HD-20	Circular	560	875	155	75	75	720	80
BPCI-5	Heavy Duty	HD-20	Circular	450	710	155	75	75	540	80
BPCI-6	Heavy Duty	HD-20	Square	600x600	920x920	155	75	75	750x750	80
BPCI-7	Heavy Duty	HD-20	Square	450x450	760x760	155	75	75	610x610	80
BPCI-8	Heavy Duty	HD-20	Rectangular	600x450	910x760	155	75	75	750x600	80
BPCI-9	Medium Duty	MD-10	Circular	560	770	110	50	50	670	60
BPCI-10	Medium Duty	MD-10	Circular	500	710	110	50	50	610	60
BPCI-11	Medium Duty	MD-10	Circular	470	680	110	50	50	570	60
BPCI-12	Medium Duty	MD-10	Circular	410	620	110	50	50	510	60
BPCI-13	Medium Duty	MD-10	Square	600X600	810X810	110	50	50	710X710	60
BPCI-14	Medium Duty	MD-10	Square	510X510	720X720	110	50	50	610X610	60
BPCI-15	Medium Duty	MD-10	Square	450x450	660x660	110	50	50	560x560	60
BPCI-16	Medium Duty	MD-10	Square	360X360	570X570	100	50	50	460X460	50
BPCI-17	Medium Duty	MD-10	Square	300X300	510X510	100	50	50	400X400	50
BPCI-18	Medium Duty	MD-10	Square	210x210	410x410	100	50	50	310x310	50
BPCI-19	Medium Duty	MD-10	Rectangular	510X410	710X610	110	50	50	610X510	60
BPCI-20	Medium Duty	MD-10	Rectangular	600X450	810X660	110	50	50	710X560	60
BPCI-21	Gully Grating	MD-10	Square	360x360	570x570	100	50	50	460x460	50
BPCI-22	Gully Grating	MD-10	Square	450x450	660x660	110	50	50	560x560	60
BPCI-23	Gully Grating	MD-10	Square	510X510	720X720	110	50	50	610X610	60
BPCI-24	Gully Grating	MD-10	Rectangular	510X410	710X610	110	50	50	610X510	60
BPCI-25	Gully Grating	HD-20	Rectangular	500x450	810x760	155	75	75	650x600	80
BPCI-26	Gully Grating	HD-20	Square	450x450	760x760	155	75	75	610x610	80

DESIGNER FLOOR CEMENT TILES

We Bhuasuni Precast Privet Limited manufacture and supply technologically highly sophisticated range of Designing floor Tiles using qualitative raw material based on latest technology mechanism. We provide our product in a variety of bright colors and numerous patterns. These product clients can avail from us at affordable Price.

These are widely used for fulfilling the flooring requirements of various places like houses and offices.

SIZE : **300 MM X 300MM X 25MM**
Grade : **M25**



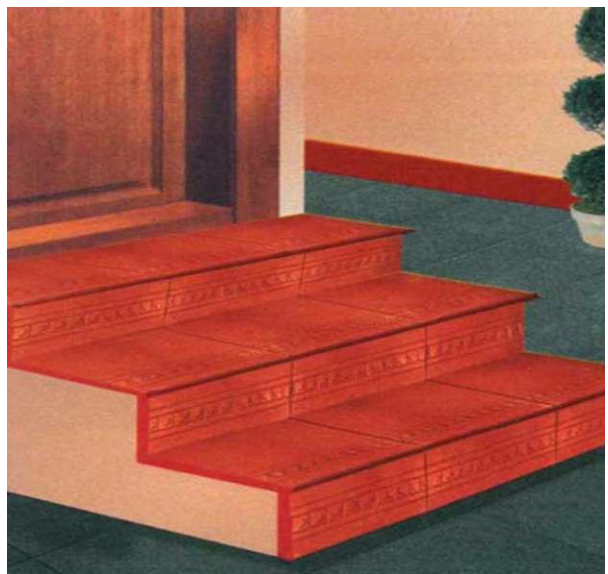
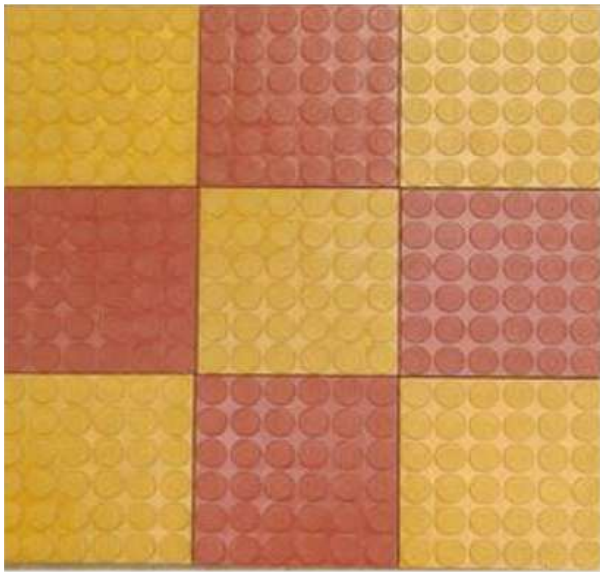
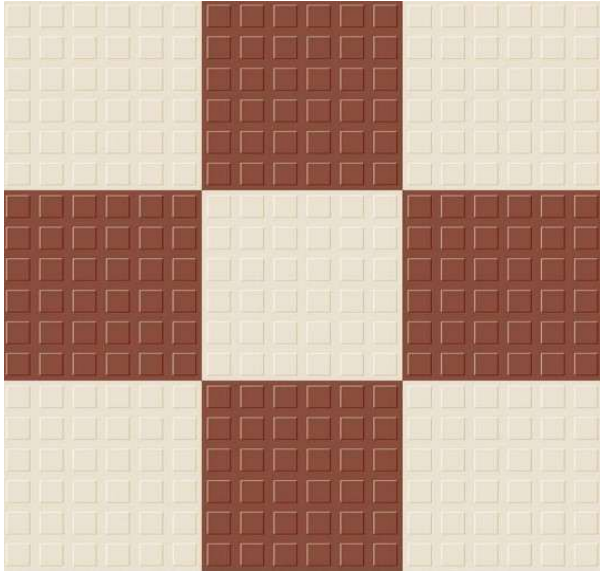

PRECAST U DRAIN & COVER SLAB

Precast concrete U drains allow for speedier construction of channels with minimum wet cast concrete work. These drains range in widths from 200 mm to 855 mm. They are produced in strict factory controlled conditions that ensure high quality. Besides storm water drainage, these types of drains are also used to house underground cables and waterlines in industrial setup.

Features of U Drain

- **M - 30** grade of concrete by vibrato compaction process.
- Suitably reinforced to promote long life.
- For Jointing, it is recommended to fill the joint between two adjacent drains with cement mortar.
- The drain should be laid on a properly compacted base.
- Heavier drains are provided with lifting Hooks.

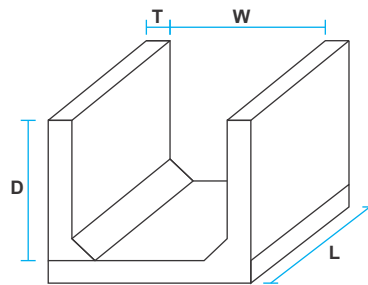

PRE CAST RCC DRAIN (M-30 GRADE)

LENGTH	WIDE (INNER)	HEIGHT (INNER)	THICK	WIDE (OUTER)	HEIGHT (OUTER)
600MM	450MM	450MM	80MM	610MM	530MM
600MM	600MM	450MM	80MM	760MM	530MM
600MM	600MM	600MM	100MM	800MM	700MM
600MM	600MM	700MM	100MM	900MM	800MM
750MM	600MM	800MM	150MM	900MM	950MM
750MM	600MM	900MM	150MM	900MM	1050MM
750MM	600MM	1000MM	150MM		1150MM
COVER SIZE 80MM THICK					



PRECAST TOILET

Our pre cast Toilet provide ,easy installation require less area, Easy installation ,less time to fulfill requirement and moreover less expensive .

FEATURES OF PRECAST TOILET

- Size: 965mm Width x 1500mm Depth x 2100 mm Height.
- Weight once assembled is 900 kgs.
- Frames & panels are manufactured from SFRC using M-30 grade concrete .
- Door is manufactured from 12mm thick laminated cement particle board Or
- Pvc door panel.
- Side panels are 40mm thick while the bottom panel is 30mm thick.
- Suitable hinges are provided for the door to swivel.
- A Unique lock is provided which is lock able from either inside or outside but never both.

CEMENT COVERBLOCK

A cover block is basically a spacer that is used to lift the rebar matrix off the ground so that concrete may flow below the rebar.

While doing RCC work it is important to embed the steel in the concrete (also known as cover) so that the rebar doesn't corrode and to provide fire protection to the rebar. If the cover is not recommended the rebar will corrode with time and will ultimately result in premature failure of the structure. Thus using cover blocks enhances the life of the structure significantly without adding much to the cost. Concrete cover blocks are frequently used in the construction of commercial developments, homes, bridges and other locations or projects requiring long-lasting, durability.

While concrete spacers are made from high strength concrete, these concrete spacers bond perfectly with the surrounding concrete.

PARAMETER	CONCRETE COVER BLOCKS
Strength	M30 and more
Wastages	No Damages
Area Coverage	200 to 250 Sq. Ft per 100 Nos.
Finishing	Concrete Finish
Bondage	As good as concrete
Mix	Design Mix

DESIGN	SIZE IN MM	COVERAGE
MULTI USER	50X40X25X20	100 PCS FOR 200 SQFT.
SINGLE USER	25X20	
HEAVY USER	65X75	
FOUNDATION USER	75X100	
ROUND FOR PAILING	50MM	
ROUND FOR COLOUM	25MM	

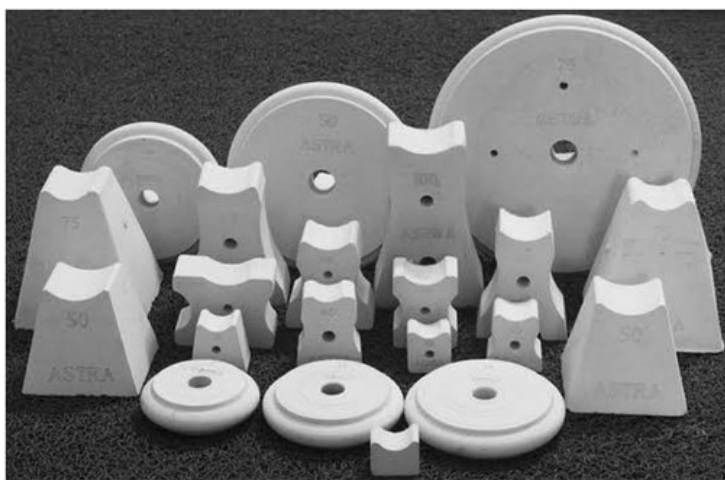

RCC DOOR & FRAME

Our Bhuasuni Cement concrete Door & Window frames can be used in all Residential as well as Commercial Buildings due to their lot of advantages.

These RCC Doorframes help in faster construction of buildings as fixing of hinges, fixtures & shutters is less tedious as compared to traditional wooden frames. RCC Doorframes are best replacement and ultimate solution to all types of doorframes available in market. The RCC Doorframe can be painted with attractive colors and patterns to make it look more decorative.

Features of RCC Door & Window frames

- Durable & all proof.
- Eco-friendly building material.
- Suitable to any type of construction & low cost housing.
- Excellent Surface finishing with Rock strength.
- Excellent Strength .
- Fire &Termite resistant.

Technical Specifications

- RCC door and window frames are ideal substitute for WOOD and MS DOOR frames.
- Available as horizontal and vertical frame sections, easy to assemble and dimensionally accurate.
- Available in 4" (inch) x 2.5" section and 5" x 2.5" section with excellent surface finish. Door rebate of 35 MM, 38 MM & 40 MM.
- Holdfast is provided on frame, provision for tower bolt, drop and door closer is made on the frame.
- Made from M-30 concrete grade mix design with proper reinforcement.
- No shrinkage or expansion like wood, economic, Eco- friendly and durable.
- Available in all sizes for entrance door, room doors, toilet doors etc. Available in all standard sizes for window frames.
- Curing by immersion in water for 15 days.
- Male-female groves are made to fix the frame in proper position.
- Iron Hinges block for fixing steel/iron hinges.
- MS Clamps fix rigidly to the wall.



RCC DOOR & WINDOW FRAMES
AVAILABLE SIZES (IN INCHES)

RCC DOOR & WINDOW FRAMES AVAILABLE SIZES (IN INCHES)				
RCC DOOR FRAME	RCC FOLDING WINDOW FRAME			
HEIGHT	WIDTH	HEIGHT	WIDTH	
78" 84"	30"	30" 36" 42" 48" 54"	30"	
	33"		36"	
	36"		42"	
	39"		48"	
	42"		54"	
	45"		60"	
	48"		72"	
DESIGNING DOOR FRAMES SIZE	SIZE OF RCC FIX WINDOW WITH GRILLS			
78" 84"	30" 36"	30" x 30"	48" x 30"	
		30" x 36"	48" x 36"	
	42" 48"	36" x 30" 36" x 36"	48" x 42"	48" x 48"
			48" x 54"	48" x 60"

TREE GUARD

Our tree Guard Provides a better solution for guarding valuable trees compare to conventional MS net structure .It prevents Rust ,More stronger and more ever can colored for beautification

Features of Tree Guard

- Consist of four panels of size 1800mm (Height) X 620mm (Width) X 25/35mm (Thickness).
- Manufactured with M-30 grade of concrete using vibro-compaction process using joint less FRP moulds so as to achieve shuttering finish.
- Suitably reinforced to promote long use and to prevent damage during handling.

Fence Majestic

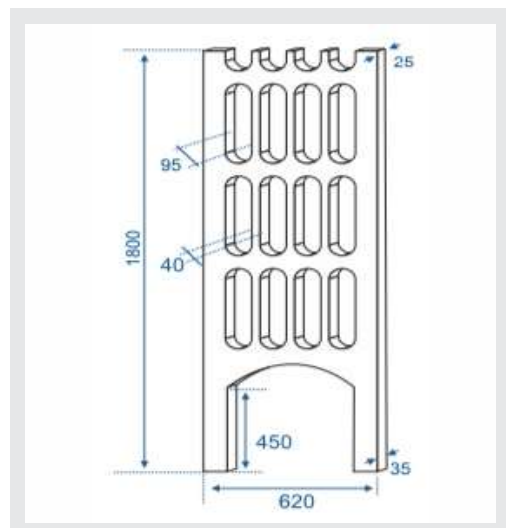
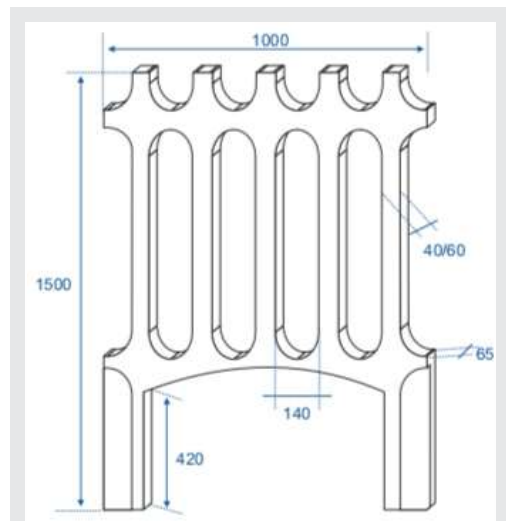

Precast Garden Bench

We deal in the RCC Bench that is weather-proof, easily installable, durable and precise. The offered Precast RCC Bench is created using the optimum quality M-30 grade of Concrete and by using vibrant-compaction process in full compliance with the industry standards. For different uses in gardens, parks, schools, colleges, resorts and many more places. These RCC Benches are offered in variable specifications at the competitive price.

Features

- Fine quality
- Easy transferable & Installation
- Affordable prices
- Timely delivery
- Colored to beautification

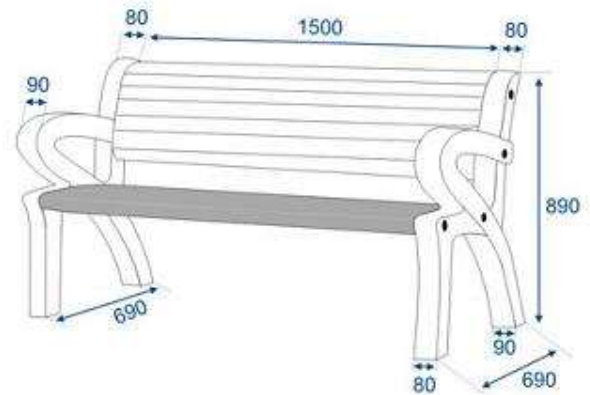
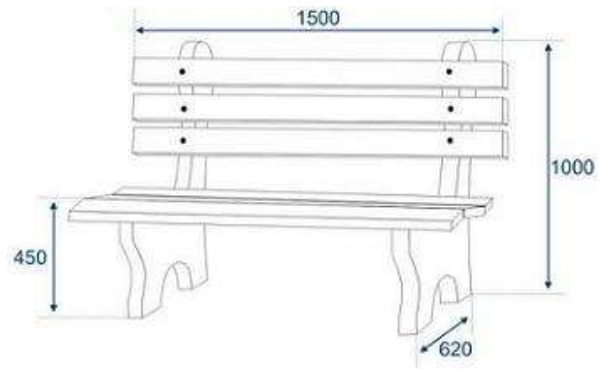





PRE STRESSED PRECAST FENCING POLE

Our PRE STRESSED PRECAST FENCING POLE are pre stressed, which involves by imposing a predetermined force in to the concrete member by special high tensile steel wires of 4 mm Dia. , Prior to hardening of the concrete. As a result, our boundary walls are free from crack, resistance to effect of impact, shock and stress.

We use 0.3 to 0.5 mm steel fiber wires as an additional ingredient, dispersed uniformly at random in small percentage other than Portland cement, aggregates and fine sand.

SL NO	SIZE IN INCH (LOWER)	SIZE IN INCH (TOP)	HEIGHT IN FEET
1	125MM X 100MM	100MM X 100MM	21000 MM
2	125MM X 100MM	100MM X 100MM	18000 MM
3	150MM X 125MM	125MM X 125MM	22500 MM



PRECAST LINTEL BEAMS

Do you spend too much time on building lintel beams for doors and windows. Well now you can save time and improve your construction quality by specifying precast lintel beams.

A lintel is a beam placed across the openings like doors, windows etc. in buildings to support the load from the structure above. The width of lintel beam is equal to the width of wall, and the ends of it is built into the wall. ... Horizontal lintels are easy to construct as compared to arches.

PURPOSES OF LINTEL BEAM:

There are the following purposes of lintel beam such as;

1. These beams are used to support the walls above the openings like windows and doors, etc.
2. As a safeguard of the windows and doors, these beams are provided.
3. These beams are provided to withstand the imposed loads coming from above blocks or bricks.
4. It is provided to transfer its load to the side walls.
5. Sometimes as decorative architectural element lintels are used.

Available Sizes		
L	W	H
1500 MM	250 MM	75 MM
1350 MM	250 MM	75 MM
1200 MM	250 MM	75 MM
1050 MM	250 MM	75 MM
900 MM	250 MM	75 MM
1500 MM	125 MM	75 MM
1350 MM	125 MM	75 MM
1200 MM	125 MM	75 MM
900 MM	125 MM	75 MM

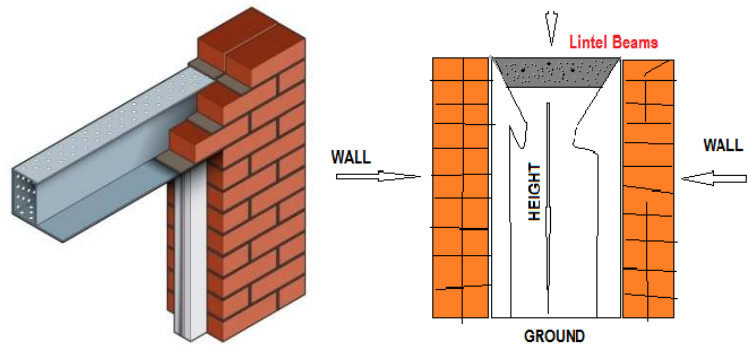

KITCHEN SLAB /RACK SLAB

Basically kitchen slab is used in kitchen for cooking based area and it was made in cement and rod ,and its not taking much time it already prepared by mason in a good quality cement and it is easy to fix in your suitable height.

AVAILABLE SIZES

1500 X 500 X 50	950 X 500 X 25	1200X250X25
1200 X 500 X 50	1500X375X25	1050X250X25
900 X 500 X 50	1350x375x25	950X250X25
1500 X 500 X 25	1200 X 375 X 25	1350X250X25
1350 X 500 X 25	1050 X 375 X 25	
1200 X 500 X 25	950 X 375 X 25	
1050 X 500 X 25	1500 X 250 X 25	



GLOBAL CERT

Certificate of Registration

This is to certify that the Quality Management System of:

BHUASUNI PRECAST PRIVATE LIMITED

Address:

PLOT NO.- 313/344, BIDANASI, CUTTACK- 753014, ODISHA, INDIA

Has been successfully assessed & conforms with the following standard

ISO 9001:2015

Scope of certification

MANUFACTURING OF CONCRETE PRODUCTS

Certificate no.: 7102HQ020

Date of issue : 27/08/2017

1st Surveillance due on : 28/08/2021

2nd Surveillance due on : 28/08/2022

* Date of Expiry : 28/08/2021

Authorized Signatory

* Subject to successful completion of surveillance Audits

Global Management Certifications

363-G, Pocket - B, Omicron-1, Greater Noida, Gautam Budh Nagar, UP, India.

Email: globalcertdelhi@gmail.com, Mob.: 9873984419

To verify this Certificate please visit at www.globalcert.co.in

GMC is accredited by IACCA, an independent accreditation board, which is not member of any accreditation association or federation.



GOVERNMENT OF INDIA
MINISTRY OF CORPORATE AFFAIRS
Central Registration Centre

Certificate of Incorporation

[Pursuant to sub-section (2) of section 7 of the Companies Act, 2013 (18 of 2013) and rule 18 of the Companies (Incorporation) Rules, 2014]

I hereby certify that BHUASUNI PRECAST PRIVATE LIMITED is incorporated on this Seventh day of March Two thousand seventeen under the Companies Act, 2013 (18 of 2013) and that the company is limited by shares.

The Corporate Identity Number of the company is U26990OR2017PTC026674.

The Permanent Account Number (PAN) of the company is AAHCB1155H *

Given under my hand at Manesar this Eighth day of March Two thousand seventeen .

Ministry of Corporate Affairs

Digital Signature Certificate

Mr MANGAL RAM MEENA

Deputy Registrar of Companies

For and on behalf of the Jurisdictional Registrar of Companies

Registrar of Companies

Central Registration Centre

Disclaimer: This certificate only evidences incorporation of the company on the basis of documents and declarations of the applicant(s). This certificate is neither a license nor permission to conduct business or solicit deposits or funds from public. Permission of sector regulator is necessary wherever required. Registration status and other details of the company can be verified on www.mca.gov.in

Mailing Address as per record available in Registrar of Companies office:

BHUASUNI PRECAST PRIVATE LIMITED

PLOT NO- 313/344, AT/PO- BIDANASI, CUTTACK, Cuttack, Orissa,
India, 753014



* as issued by the Income Tax Department

OUR SISTER CONCERNS

BHUASUNI PRECAST CEMENT INDUSTRIES

Deals with House hold Precast Product

MAA BHUASUNI ENTERPRISES

Deals with Cement, JK Putty, JK White Cement, Pidilite

BHUASUNI TRADING CO.

Deals with Abro Adhesive Tape, Sheenlac, Barbed wire & Concertina Wire

Bhuasuni Precast Private Limited

📍 Bidanasi, Bandha Chhak, Cuttack-753014, Odisha

☎ 0671-2504594, 94398 14949

✉ bhuasuniprecast@gmail.com 🌐 www.bhuasuniprecast.com